

RY2000 EXTREME PUNCH MACHINE *Rytan* INCORPORATED

1648 W 134th. St.
Gardena, CA
90249 U.S.A.
www.rytan.com
800-447-9826

USER MANUAL

PORTABLE
SHIPPING WEIGHT
UNDER 15lbs

**MORE THAN A
DOZEN KEYWAY
COMBINATIONS**

SEE PAGE 4

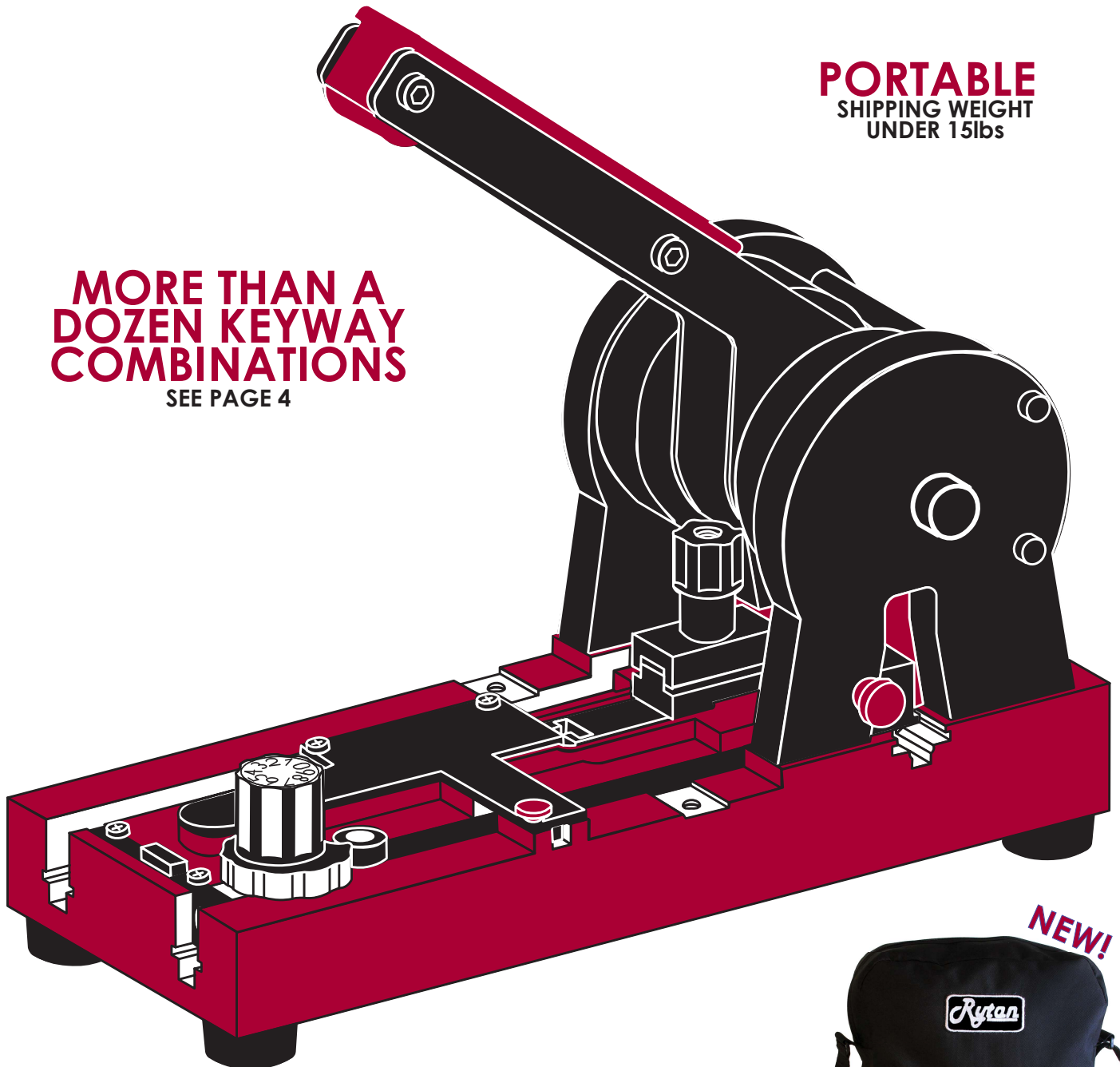

**ORDER A CARRYING
CASE TODAY!**

RY2000CASE - Call for pricing



MUST BE PURCHASED SEPARATELY

RY2000 PUNCH MACHINE USER MANUAL

Rytan²
INCORPORATED

1648 W 134th. St.
Gardena, CA
90249 U.S.A.
www.rytan.com
800-447-9826

1. GETTING READY TO LOAD A KEY. Push the handle down all the way and then let the handle come back up (controlled release). Repeat pushing the handle down and letting it come back up until the Vise Jaw Assembly is all the way forward (closest to you).

2. INSERT YOUR KEY BLANK. Loosen the Key Clamp Knob until you can insert your key blank. As you slide the key blank into the vise jaw, press the entire length of the blade against the vise jaw. Press until the bottom shoulder is resting firmly against the jaw and tighten the Key Clamp Knob while pressing.

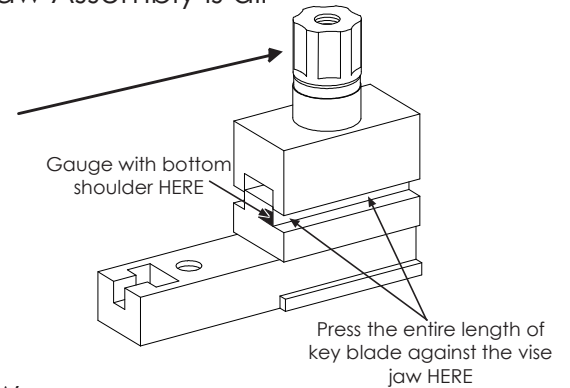

3. PREPARE FOR FIRST CUT. Push the key and the Vise Jaw forward until they are all the way into the machine. You will hear a “ratcheting” sound as you push the assembly back. **PUSH FROM THE BOTTOM OF THE VISE JAW ASSEMBLY!**

4. MAKE YOUR FIRST CUT. Select the code number for the first cut in the key, closest to the shoulder (the bow of the key). Use the depth selector code wheel. Push the handle all the way down and then let the handle come back up with a controlled release. Your first code cut has been made!

5. FOLLOWING CUTS. When you let up on the handle with each cut, the Key and Vise Jaw will automatically step toward you into the next cut position. Select your next code number to cut into the key. Press the handle down and release, as in step 4.

6. REPEAT. Repeat steps 4 and 5 until you have completed cutting your key.

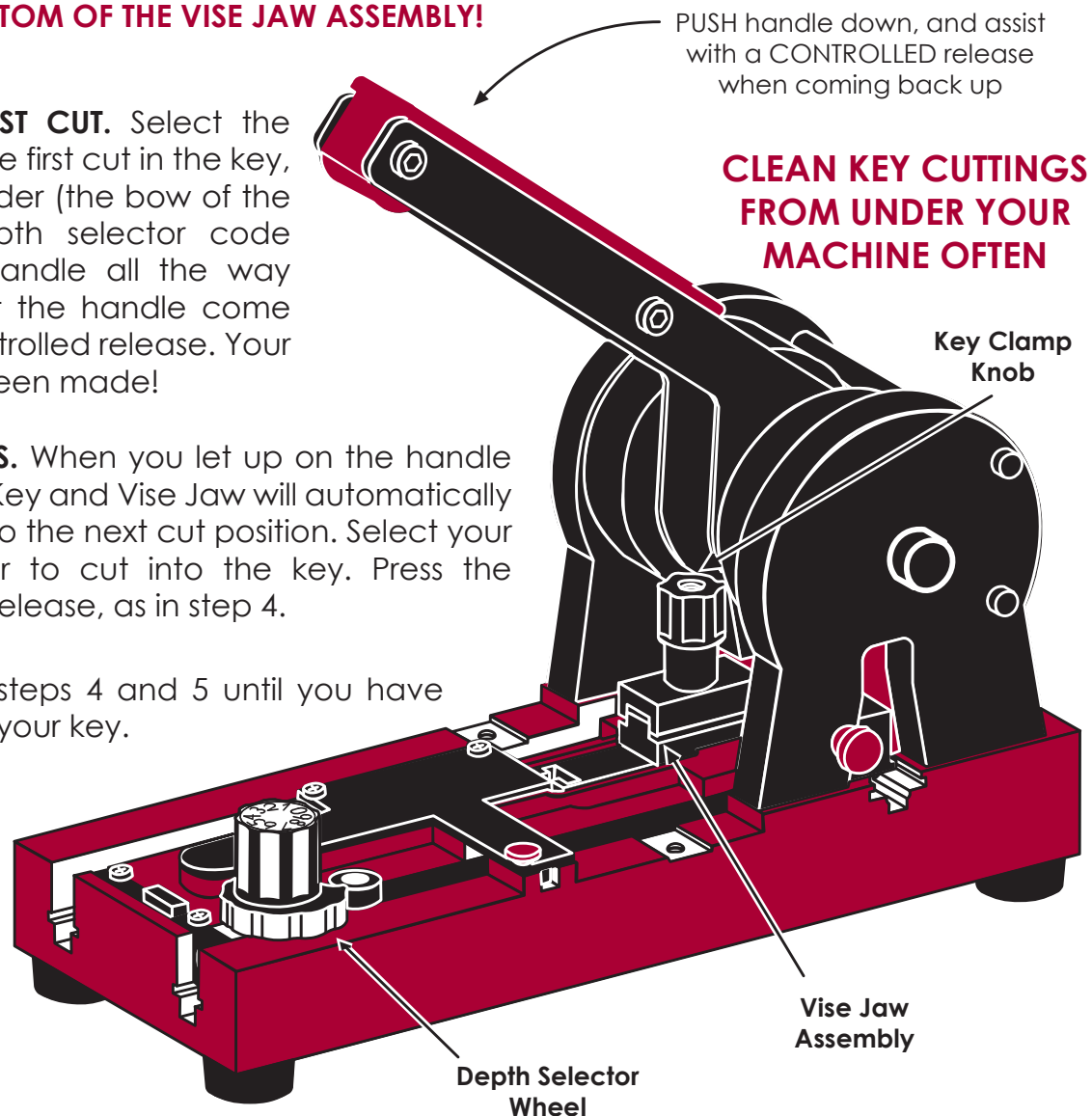

RY2000 PUNCH MACHINE USER MANUAL *Rytan*³ SPACE ADJUSTMENT & DEPTH ADJUSTMENT

INCORPORATED

SPACE ADJUSTMENT

Turning the 3/32" Allen Wrench **CLOCKWISE** (double arrow illustrated below) will make your key cuts **CLOSER TO THE BOW** of the key.

Turning the 3/32" Allen Wrench **COUNTER CLOCKWISE** (single arrow illustrated below) will make your key cuts **CLOSER TO THE TIP** of the key.

DEPTH ADJUSTMENT

Turning the 3/32" Allen Wrench **CLOCKWISE** (double arrow illustrated below) will make your key cuts **MORE SHALLOW**.

Turning the 3/32" Allen Wrench **COUNTER CLOCKWISE** (single arrow illustrated below) will make your key cuts **DEEPER**.

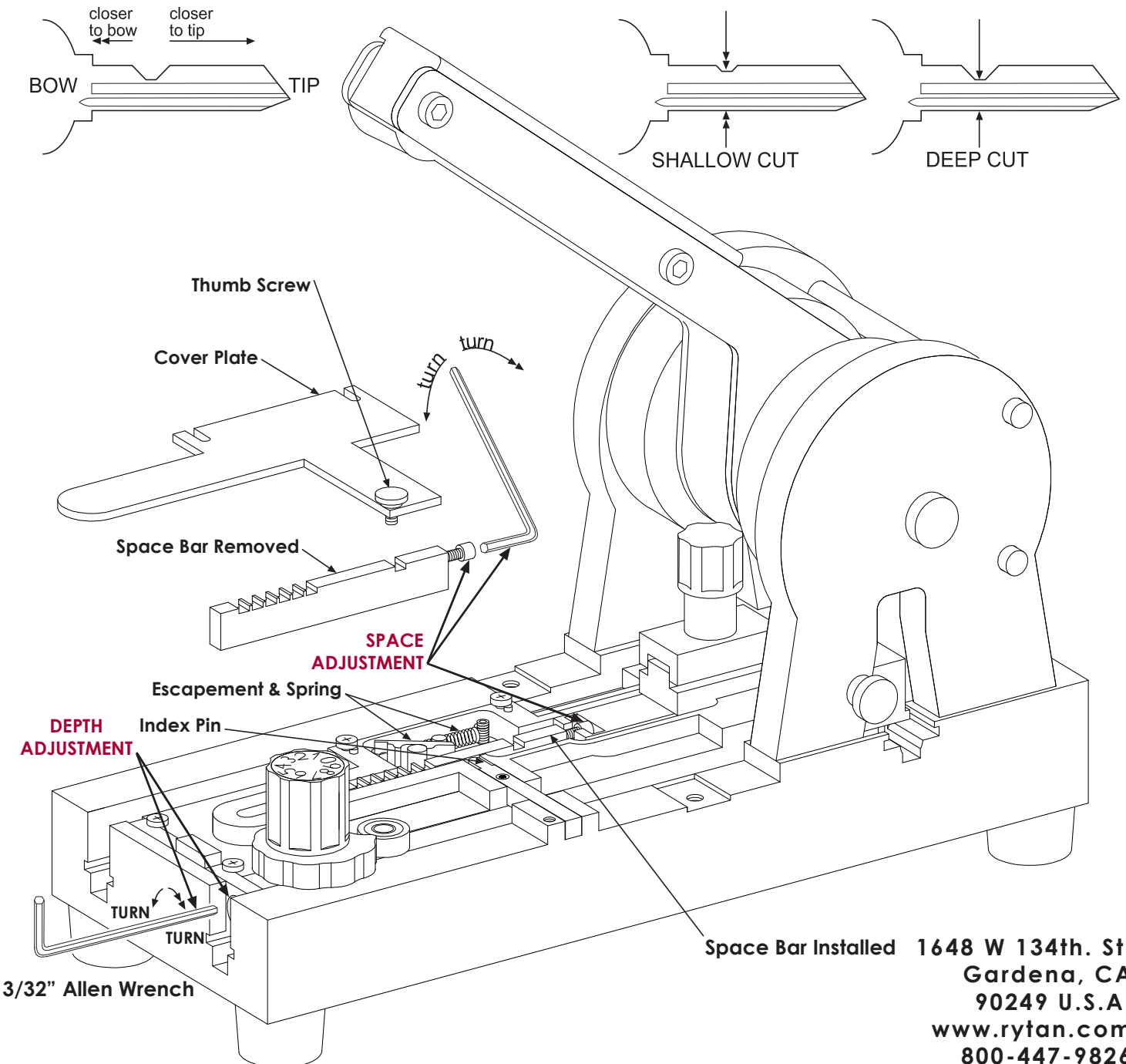

Space Bar Installed 1648 W 134th. St.
Gardena, CA
90249 U.S.A.
www.rytan.com
800-447-9826

RY2000 PUNCH MACHINE USER MANUAL *Rytan*⁴ QUICK-KIT COMPONENTS

ONE MACHINE - DOZENS OF OPTIONS! Schlage on the RIGHT, and keyway of your choice on the LEFT

1648 W 134th. St.
Gardena, CA
90249 U.S.A.
www.rytan.com
800-447-9826

To add new keyways to your machine, see below table. Find the keyway you want in the first column and order the parts in that row. If you already have dual capabilities, you do NOT need an additional 2026RH/LH Depth Driver or RY2007 Top Vise Jaw.

KEYWAY	DEPTH SELECTOR ASSEMBLY	SPACE BAR ASSEMBLY	PUNCH & DIE ASSEMBLY	DEPTH DRIVER (RH or LH)	TIP STOP ASSEMBLY	TOP SHOULDER STOP ASSEMBLY	TOP VISE JAW
RY2000ARW ARROW	RY5070DS	RY4070SB	RY6070PD	RY2026LH		RY2075TSS	RY2007AF
RY2000M-M1 MASTER	RY5071DS	RY4071SB	RY6071PD	RY2026LH		RY2075TSS	RY2007 RY2006M1*
RY2000CO70 CORBIN	RY5073DS	RY4073SB	RY6073PD	RY2026LH		RY2075TSS	RY2007
RY2000DEX DEXTER	RY5074DS	RY4074SB	RY6074PD	RY2026LH		RY2075TSS	RY2007
RY2000KMARK KEYMARK	RY5075DS	RY4075SB	RY6075PD	RY2026LH		RY2075TSS	RY2007B RY2006KM*
RY2000A2/A3/A4 BEST/I-CORE	RY5076DS RY5077DS RY5078DS	RY4078SB	RY6078PD	RY2026LH	RY2015TS		RY2007B
RY2000KW KWIKSET	RY5079DS	RY4079SB	RY6079PD	RY2026LH			RY2007
RY2000SCH SCHLAGE CLASSIC, REVERSE, AND EVEREST	RY5090DS	RY4090SB	RY6090PD	RY2026RH (LH for reverse)			RY2007
RY2000WEI WEISER	RY5094DS	RY4094SB	RY6094PD	RY2026LH		RY2075TSS	RY2007
RY2000WES WESLOCK	RY5095DS	RY4095SB	RY6095PD	RY2026LH		RY2075TSS	RY2007

RY2000MX4_
MEDECO

CONTACT RYTAN FOR PART NUMBERS AND INFORMATION

*KEYMARK & MASTER M1 require custom vise bases that differs from all other machine models



RY2075TSS
Top Shoulder stop assembly

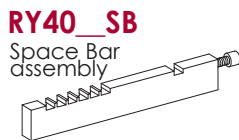

RY40_SB
Space Bar assembly



RY2015TS
Tip Stop

RY50_DS
Depth Selector assembly

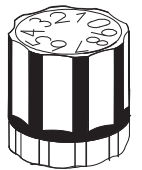

RY2007_
Top Vise Jaw

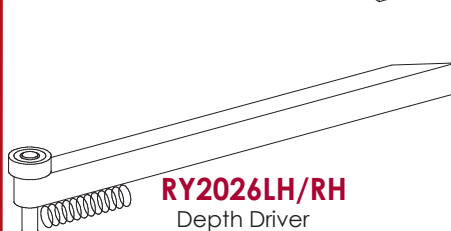

RY2026LH/RH
Depth Driver

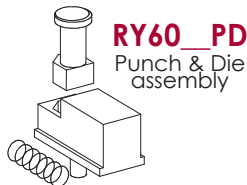

RY60_PD
Punch & Die assembly



RY2056
DUAL Punch Stop



RY2092
Punch & Die Retaining Screw

ORDERING EXAMPLE: You have a single punch machine with Schlage capabilities. You want to be able to punch the Kwikset keyway. Order everything in the **RY2000KW** row, EXCEPT the RY2007 vise jaw. Your machine already has the RY2007 since you have the parts that correspond with Schlage. You will keep Schlage set up on the right side of your RY2000, and Kwikset set up on the left. When switching between the keyways, you will only need to swap out the space bar! Same goes with the RH or LH Depth driver - no need to purchase duplicates.

RY2000 PUNCH MACHINE USER MANUAL *Rytan*⁵ CHANGING QUICK-KIT COMPONENTS

1648 W 134th. St.
Gardena, CA
90249 U.S.A.
www.rytan.com
800-447-9826

NOTE: For Dual machining, Schlage and ONLY Schlage is installed on the right side. All other keyways and components are installed on the left. Always change corresponding quick-kit components when jumping between keyways.

RY50_DS: Depth Selector Assembly & RY2026_H: Depth Driver Assembly

Perform these steps in reverse to install components for a different keyway

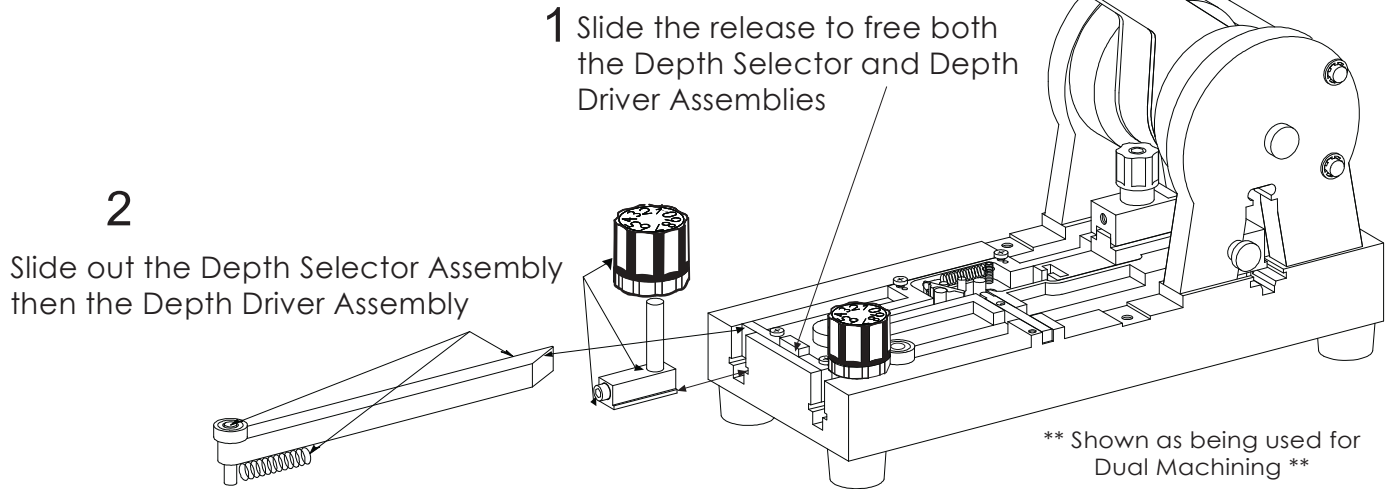

RY60_PD: Punch & Die Assembly

Perform these steps in reverse to install components for a different keyway

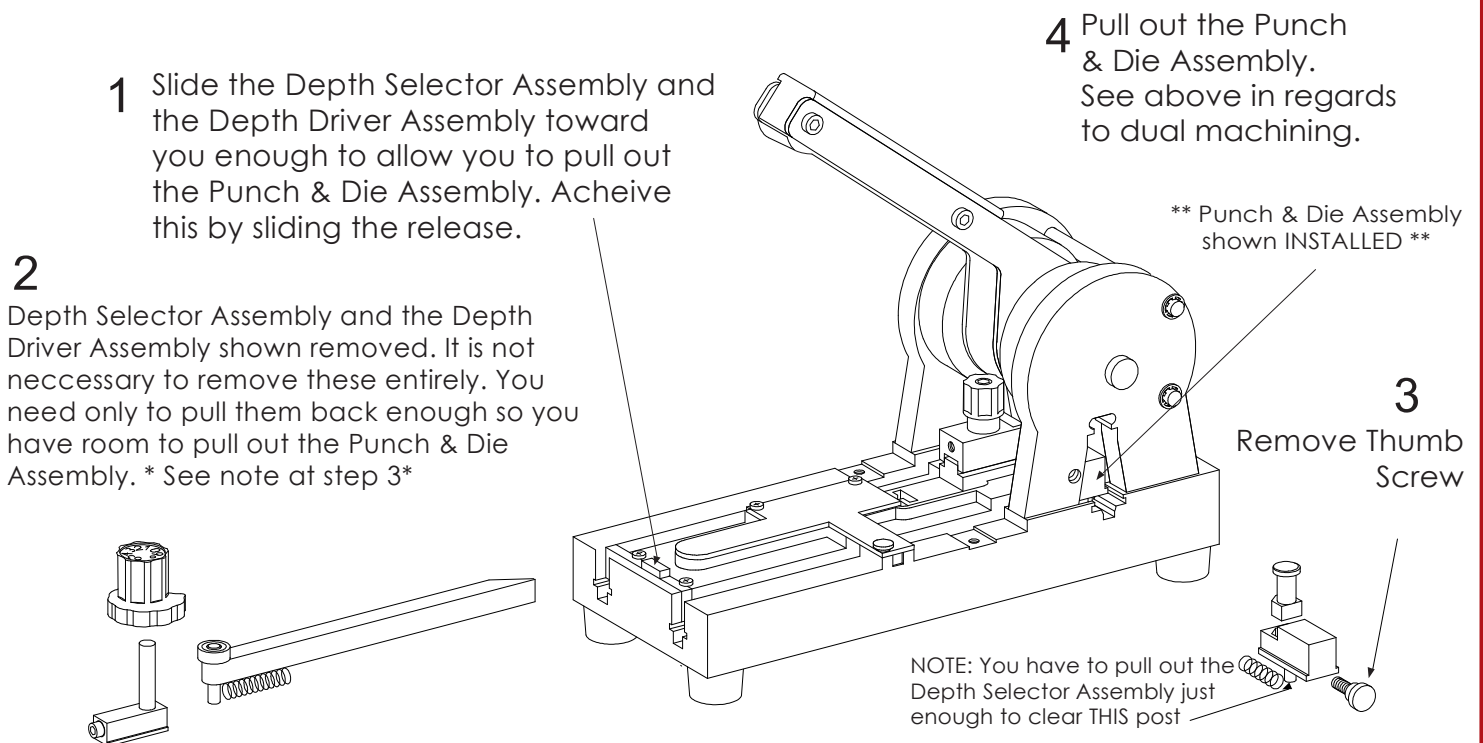

RY2000 PUNCH MACHINE USER MANUAL *Rytan*⁶ CHANGING QUICK-KIT COMPONENTS

1648 W 134th. St.
Gardena, CA
90249 U.S.A.
www.rytan.com
800-447-9826

RY40__SB: Space Bar Assembly

- 1
Loosen the thumbscrew
and remove Cover Plate

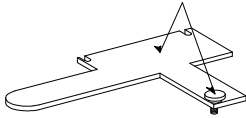

- 3
Replace it with new
Spacebar Assembly &
reinstall the thumbscrew
and cover plate

- 2
Lift out the Space
Bar Assembly

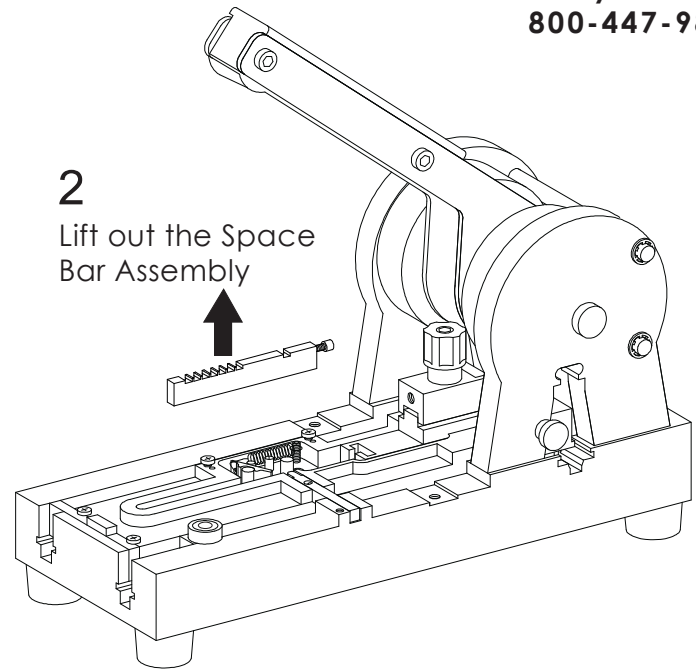

RY2007: Vise Jaw Assembly

How to install & add RY2015 Tip Stop on your RY2000 I-Core/Best Punch Machine
Perform these steps in reverse to install RY2007AF and RY2007B Vise Jaw Assembly

- 1
Loosen the thumbscrew
and remove Cover Plate

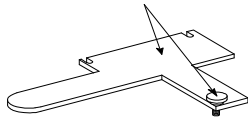

- 2
Lift out the Space
Bar Assembly

- 4
Slide the Vise Assembly toward you
then lift it out of the machine

- 5
Install RY2015TS onto
back of vise as shown using
a 3/32" allen wrench.

NOTE: If you are just installing the RY2015TS, you can
avoid removing the Vise Jaw Assembly from the
machine by using a long 3/32" allen wrench from
the back of the machine and installing it
as shown in step 5.

** RY2015TS is used ONLY for
Best/I-core Keyway **

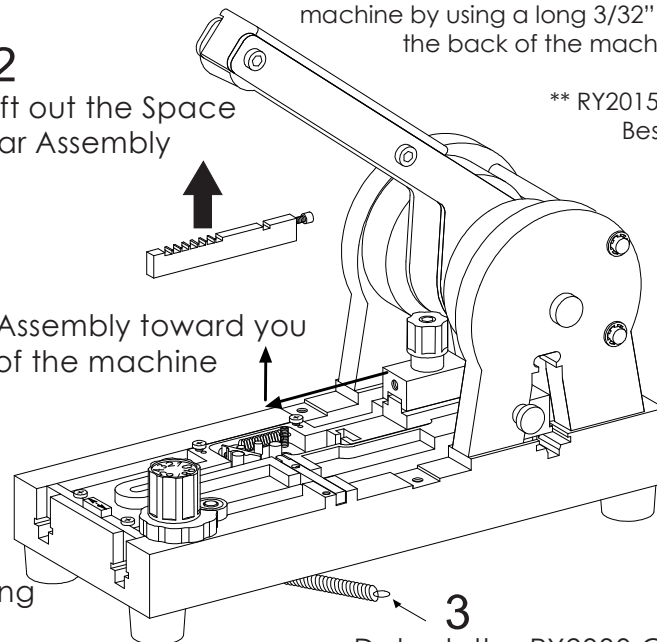

- 3
Detach the RY2030 Carriage Spring

RY2000 PUNCH MACHINE USER MANUAL **Rytan**⁷ CHANGING QUICK-KIT COMPONENTS

NOTE: For Dual machining, Schlage and ONLY Schlage is installed on the right side. All other keyways and components are installed on the left. Always change corresponding quick-kit components when jumping between keyways.

1648 W 134th. St.
Gardena, CA
90249 U.S.A.
www.rytan.com
800-447-9826

RY2075TSS: Top Shoulder Stop Assembly

NOTE: RY2075TSS is used ONLY for Arrow, Corbin, Weiser and Weslock keyways

1. Install Top Shoulder Stop as shown. Be sure spring washer is under the head of the screw.
2. Screw the parts together until the Spring Washer starts to compress.
3. Stop tightening the screw when you feel resistance to the Top Shoulder Stop. Adjust tension as necessary.

DO NOT OVERTIGHTEN THE SCREW

Overtightening the screw will make the Top Shoulder Stop stiff to operate.

Not tightening it enough may affect key cutting position when gauging and punch cutting the key.

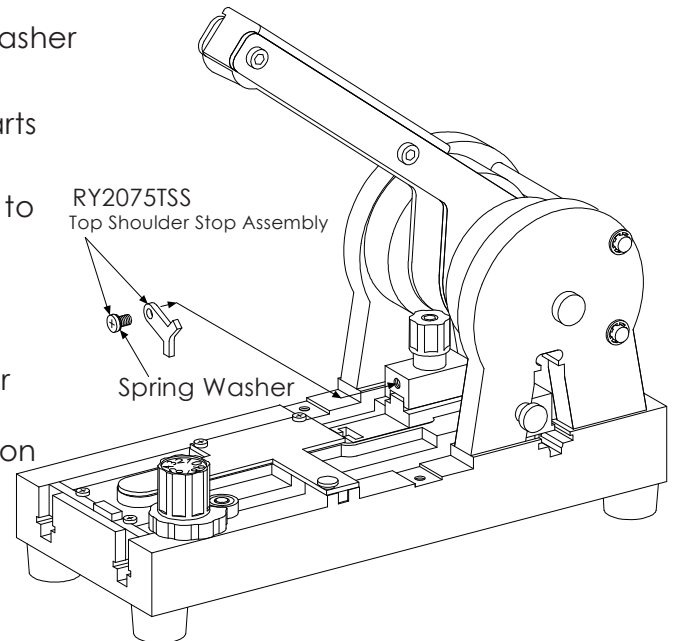

RY2000 PUNCH MACHINE WARRANTY

Rytan, Inc. Model RY2000 Punch Machines are warranted to be free from manufacturing defects for one year from date of purchase. During the first year, defective parts will be replaced without charge for parts or labor. Machines must be returned to the Rytan, Inc. factory for all warranty work. This warranty is not applicable to damage caused by user error, or to machines which have been altered or repaired by outside sources, or have been subject to neglect, abuse, misuse, or accident (including shipping damages). Warranty must be sent to Rytan, Inc via mail or email to customer_service@rytan.com within 10 days of purchase.

This warranty is exclusive and replaces all other warranties, including those of merchantability and fitness for a particular purpose. Rytan, Inc. will not be liable for any other damages or loss including incidental or consequential damages from whatever cause, including breach of warranty or negligence.

SERVICE: Machines sent to the Rytan, Inc. factory for service outside of warranty must be accompanied by proof of purchase or ownership. Payment of all shipping and handling costs are the customer's responsibility.